



Specifications	
Standards/approvals	EN60204-1 with switching to meet EN60947-5-1, DIN VDE 0660-200, IEC 60947-5-1
Degree of protection	EN 60529 IP67 (IP68 upon request)
Connection method	Screw terminals, stripped cable cores or connector of your choice
Electrical rating	See table below
Contact configuration	See table below
Operating temperature range	-25°C to +60°C
Body material	Die cast aluminium
Weight	Cover/unguarded 1Kg or 1.5Kg guarded
Average mechanical life	1 x 10 ⁶ operations
Additional information	the electrical housing has an environmental rating of IP67. To achieve this, a minimum torque of 1.7N should be applied to the two enclosure screws



General specifications

	Options A & B			Options D	
Rated operating voltage	500V AC, over 380V AC same potential only				
Rated operational current	AC 40 - 60 Hz			AC 50 - 60 Hz	
	Le/AC-12	Ue	Le/AC-15	Ue (V)	Le/AC-15 (A)
	(A)	(V)	(A)	230	3
	10	24	10		
	10	125	10		
	10	230	6		
	10	400	4		
	10	500	3		
Note: When the footswitch is supplied with a pre-wired cordset, the cordset rating takes precedence over the footswitch rating. The rating will be marked on the cordset					
Electrical Life Expectancy at Category AC-15	0.5 X 10 ⁶ switching cycles when interrupting 6A AC-15 at 250V				
Contact configuration	Normally open + normally closed positive opening operation to EN 60947-5-1				
Contact Gap	>3mm, suitable for mains isolation				
Terminals	Screw terminals and self-lifting clamp for connection of flexible leads; min. 2 x 1.5 mm ² - max. 2 x 2.5 mm ²			Screw terminals for connection of flexible lead wire; min. 1 x 0.5 mm ² - max. 2 x 2.5 mm ²	
Action Type from Order Code	A	B	D	E	MB
Limit switch action	1 Pole Slow Make - Slow Break	1 Pole Snap Action	2 Pole Snap Action	2 Pole Slow Make - Slow	Double snap action



Dimensions

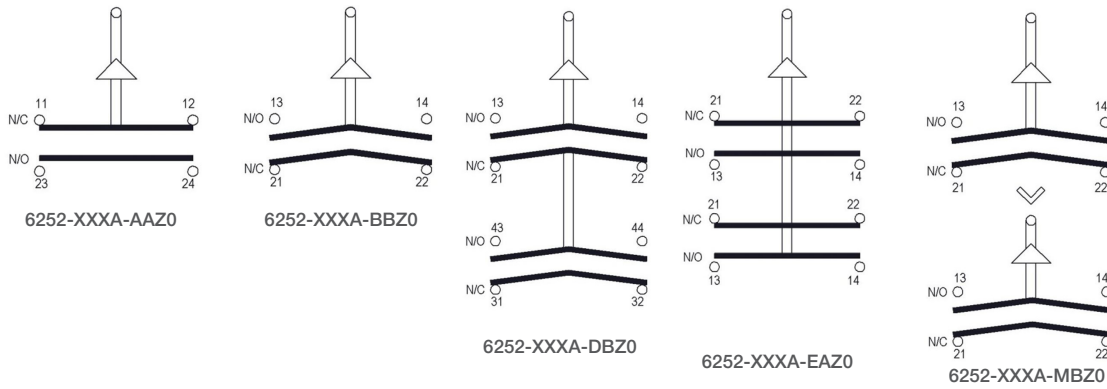
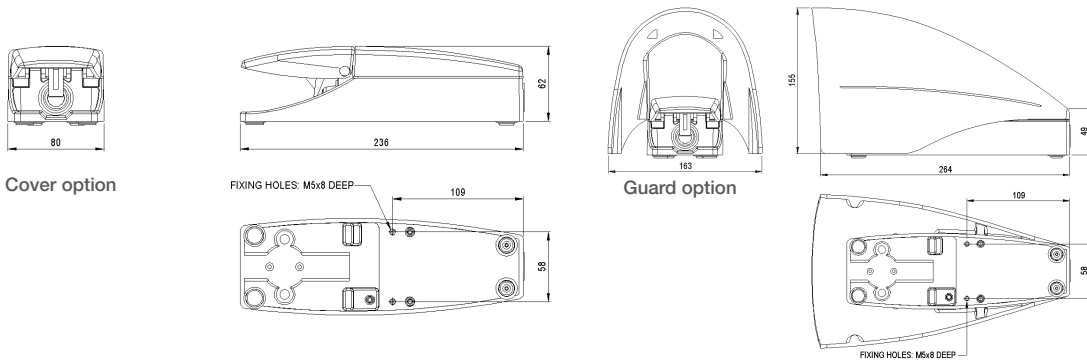

In all applications except where protective extra low voltage (PELV) circuits are being switched, an earth conductor must be installed. The earth conductor should be rated in accordance with the prevailing standards.



Ordering information

(Please use the characters in the chart below to create your product code)

Sample Code 6252 - A A A A - AA Z 0

Cover and guard colours

A	Cover Yellow
B	Guard Yellow
C	Cover White
D	Guard White
E	Cover Blue
F	Guard Blue

Base colour

A	Black
B	White

Thread/ Hole information

A	M20 Rear hole
B	PG 13,5 Rear hole
C	PG 13,5 Rear hole with double M20 side holes
D	PG 13,5 Rear hole with double PG 13.5 side holes

Tread colour

A	Black
---	-------

Action/Electrical rating*

AA	DPST Single Operation, Slow Break & Make ; AC-15 6A 250V
BB	DPST Single Operation, Snap Break & Make ; AC-15 6A 250V
DB	4PST Double Operation, Snap Break & Make ; AC-15 6A 250V
EA	4PST Double Operation, Slow Break & Make ; AC-15 6A 230V
MB	DPST + DPST staggered Double Action (High Force), Snap Break & Make ; AC-15 6A 230V

Emergency stop

Z	No emergency stop fitted
---	--------------------------

Stock models : 6252-AAAA-AAZO
6252-BAAA-AAZO

If you require a customized solution for your program contact our sales team.